



Short communication

## Calculation of the current efficiency of the electrolytic sodium chlorate cells

B.V. TILAK<sup>1</sup> and C.-P. CHEN<sup>2</sup>

<sup>1</sup>68 Dolphin Drive, Grand Island, New York 14072, USA

<sup>2</sup>Occidental Chemical Corporation, Technology Center, 2801 Long Road, Grand Island, New York 14072, USA

Received 7 December 1998; accepted in revised form 30 March 1999

**Key words:** current efficiency, energy consumption, material balance, oxygen cathodes, sodium chlorate

### List of symbols

<p>f, d, o superscripts 'f' and 'd' refer to feed and depleted brine and 'o' for the cell gas</p> <p><math>C_{\text{species}}^{\text{source}}</math> concentration of species (noted in the subscript) in the source stream (noted in the superscript) (<math>\text{mol dm}^{-3}</math>)</p> <p><math>F</math> Faraday number (<math>96\,487\text{ C mol}^{-1}</math>)</p>	<p><math>I</math> load (kA)</p> <p><math>J_{\text{species}}^{\text{source}}</math> molar flow rate of species (noted in the subscript) in the source stream (noted in the superscript) (<math>\text{mol s}^{-1}</math>)</p> <p><math>p</math> feed brine flow rate (<math>\text{dm}^3\text{ s}^{-1}</math>)</p> <p><math>q</math> depleted brine flow rate (<math>\text{dm}^3\text{ s}^{-1}</math>)</p> <p><math>\%O_2</math> Nitrogen-free oxygen in the cell gas = Measured value of <math>\%O_2 - 0.2658\%N_2</math></p>
--	---

### 1. Introduction

One of the growing and energy intensive electrolytic operations is the manufacture of sodium chlorate [1, 2]. The energy consumption ( $P$  in  $\text{kW h tonne}^{-1}$ ) involved in the electrolytic sodium chlorate process is calculated from the current efficiency ( $\eta_{\text{ClO}_3}$ ) and the directly measured cell voltage ( $V$  in V) as

$$P = \frac{1510 V}{\eta_{\text{ClO}_3}} \quad (1)$$

The current efficiency is routinely estimated in the industry from the cell gas composition using the relationship, Equation 2, proposed by Jaksic et al. [3] based on the material balance across the electrolytic cell:

$$\eta_{\text{ClO}_3} = \frac{100 - 3\%O_2 - 2\%Cl_2}{100 - \%O_2 - \%Cl_2} \quad (2)$$

Equation 2 has been simplified further by the sodium chlorate technology suppliers [1] by means of a binomial expansion followed by omitting the small terms. This results in Equation 3:

$$\eta_{\text{ClO}_3} = 100 - 2\%O_2 - \%Cl_2 \quad (3)$$

The objectives of this brief communication are: (i) to derive a rigorous expression for  $\eta_{\text{ClO}_3}$ , following a material balance formation similar to that employed for diaphragm and membrane cell chlor-alkali operations [4] and for mercury cells [5]; (ii) to extend the expression for  $\eta_{\text{ClO}_3}$  to electrolytic sodium chlorate cells operating with oxygen cathodes; and (iii) to address the limitations of Equations 2 and 3.

### 2. Theory

#### 2.1. Process chemistry

Sodium chlorate is produced by the electrolysis of NaCl as described by the overall chemical reaction (Equation 4), which requires six faradays of electricity to produce 1 g mol of  $\text{NaClO}_3$  at 100% efficiency:

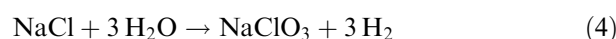

The primary electrochemical reactions occurring in a chlorate cell are the discharge of  $\text{Cl}^-$  ions to produce  $\text{Cl}_2$  at the anode and water molecules to generate  $\text{H}_2$  at the cathode as:

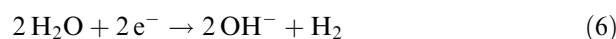

Chlorine gas evolved at the anode,  $\text{Cl}_2(\text{g})$ , dissolves to form soluble chlorine,  $\text{Cl}_2(\text{s})$ , which hydrolyses to form  $\text{HOCl}$  and  $\text{OCl}^-$ . The  $\text{HOCl}$  and the  $\text{OCl}^-$  react further to form  $\text{ClO}_3^-$ , as described by the following reaction scheme:



In Equation 7,  $\text{Cl}_2(\text{g})$  refers to the gaseous chlorine and  $\text{Cl}_2(\text{s})$  to the soluble chlorine.



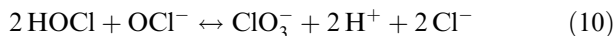

There are several parasitic reactions occurring at the cathode, the anode and in the bulk [1].

## 2.2. Derivation of chlorate current efficiency expressions

### 2.2.1. Direct method

The chlorate current efficiency, defined as the ratio of the amount of chlorate exiting the electrolyser to the theoretically expected quantity of chlorate, can be expressed as

$$\eta_{\text{ClO}_3} = \frac{J_{\text{NaClO}_3}^d - J_{\text{NaClO}_3}^f}{I/6F} \quad (11)$$

This approach requires a knowledge of the flow rates, concentrations of the chlorate in the feed and the discharge of the chlorate system and the applied current. However, this procedure is not practiced in the industry to calculate  $\eta_{\text{ClO}_3}$  on a daily basis, as it is more difficult and less accurate (due to errors in the measurement of flow rates and the total current) than the  $\eta_{\text{ClO}_3}$  calculated using Equation 2. The advantages of using Equation 2 or the other 'indirect' equations deduced in the following Section include rapidity, accuracy of measuring  $\eta_{\text{ClO}_3}$  and, more importantly, a measure of the percentage of  $\text{O}_2$  in cell gas. A discussion of the importance of the percentage of  $\text{O}_2$  in cell gas, as related to the safety aspects of plant operations, is beyond the scope of this communication [1].

### 2.2.2. Indirect methods

An indirect approach to measure the chlorate current efficiency stems from the material balance (i.e., input + generation – loss = output) of the Cl,  $\text{Cl}_2$ , Na, or OH species across the chlorate system (see Figure 1 for a schematic of the overall chlorate process and [1] for details).

(a) *Cl Species balance.* From the atomic chlorine material balance described by Equations 12–14:

$$\text{Input} = J_{\text{NaCl}}^f + J_{\text{NaClO}_3}^f + 2J_{\text{Cl}_2}^f + J_{\text{HCl}}^f \quad (12)$$

$$\text{Generation} = \text{Loss} = 0 \quad (13)$$

$$\text{Output} = J_{\text{NaCl}}^d + J_{\text{NaClO}_3}^d + 2J_{\text{Cl}_2}^o \quad (14)$$

the chlorate current efficiency can be shown to be

$$\eta_{\text{ClO}_3} = \frac{\Delta J_{\text{NaCl}} + J_{\text{HCl}}^f}{I/6F} - \frac{2(J_{\text{Cl}_2}^o - J_{\text{Cl}_2}^f)}{I/6F} \quad (15)$$

where  $\Delta J = J^f - J^d$ ;  $J^f = pC^f$  and  $J^d = qC^d$ .

(b)  *$\text{Cl}_2$  Species balance.* Similarly, from the material balance of the  $\text{Cl}_2$  species (Equations 16–19),

$$\text{Input} = 3J_{\text{NaClO}_3}^f + J_{\text{Cl}_2}^f \quad (16)$$

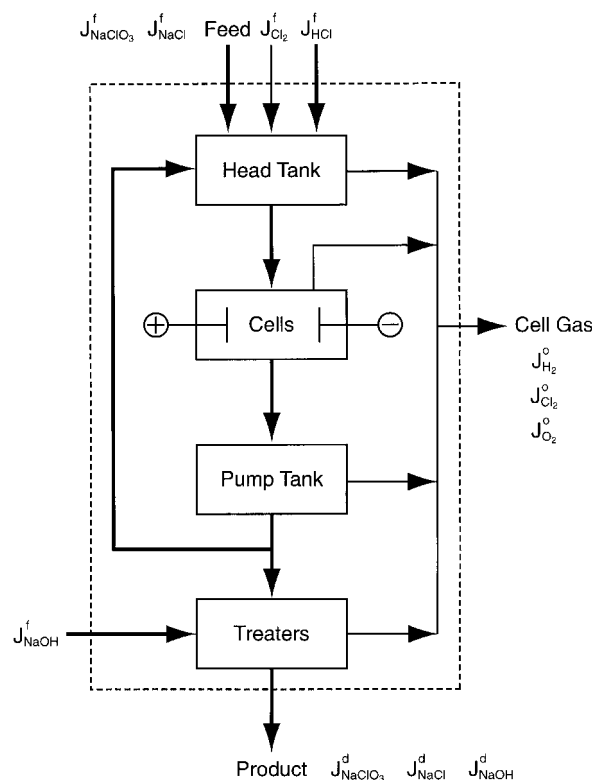

Fig. 1. Schematic of the chlorate cell process.

$$\text{Generation} = I/2F - 2J_{\text{O}_2}^e \quad (17)$$

$$\text{Loss} = 2J_{\text{O}_2}^c \quad (18)$$

$$\text{Output} = 3J_{\text{NaClO}_3}^d + J_{\text{Cl}_2}^o \quad (19)$$

the chlorate current efficiency can be shown to be

$$\eta_{\text{ClO}_3} = 1 - \frac{2(J_{\text{Cl}_2}^o - J_{\text{Cl}_2}^f) + 4J_{\text{O}_2}^o}{I/F} \quad (20)$$

where  $J_{\text{O}_2}^o$  represents the total rate of  $\text{O}_2$  generation from both electrochemical and chemical reactions, denoted by e and c in the superscripts in Equation 21:

$$J_{\text{O}_2}^o = J_{\text{O}_2}^e + J_{\text{O}_2}^c \quad (21)$$

(c) *Na Species balance.* Chlorate current efficiency can also be calculated from the material balance of the Na species described by Equations 22–24:

$$\text{Input} = J_{\text{NaCl}}^f + J_{\text{NaClO}_3}^f + J_{\text{NaOH}}^f \quad (22)$$

$$\text{Generation} = \text{Loss} = 0 \quad (23)$$

$$\text{Output} = J_{\text{NaCl}}^d + J_{\text{NaClO}_3}^d + J_{\text{NaOH}}^d \quad (24)$$

Thus,

$$\eta_{\text{ClO}_3} = \frac{\Delta(J_{\text{NaCl}} + J_{\text{NaOH}})}{I/6F} \quad (25)$$

(d) OH Species balance. Similarly, from the material balance of the OH species (Equations 26–29),

$$\text{Input} = 6J_{\text{NaClO}_3}^f + J_{\text{NaOH}}^f + J_{\text{HCl}}^f \quad (26)$$

$$\text{Generation} = I/F \quad (27)$$

$$\text{Loss} = 4J_{\text{O}_2}^o \quad (28)$$

$$\text{Output} = 6J_{\text{NaClO}_3}^d + J_{\text{NaOH}}^d \quad (29)$$

Thus,

$$\eta_{\text{ClO}_3} = 1 - \frac{4J_{\text{O}_2}^o}{I/F} + \frac{\Delta J_{\text{NaOH}} - J_{\text{HCl}}^f}{I/F} \quad (30)$$

### 3. Results and discussion

#### 3.1. $\eta_{\text{ClO}_3}$ with HCl and Cl<sub>2</sub> additions

In chlorate cells, all the chlorine generated at the anode is not converted to chlorate, since part of this chlorine escapes with the cell gas (containing O<sub>2</sub> and H<sub>2</sub>) leading to a decreased efficiency for chlorate formation. Furthermore, this loss of chlorine results in a steady increase of the pH of the cell liquor. Since the optimal pH for chlorate formation is in the range 5.9–6.7, the pH imbalance arising from Cl<sub>2</sub> losses should be compensated by HCl or Cl<sub>2</sub> addition [1]. Ideally, the cell pH should be at near neutral values since the OH<sup>−</sup> generated at the cathode via Equation 31 is consumed by the chlorine to form chlorate, according to the reaction scheme 32.

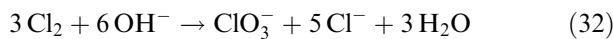
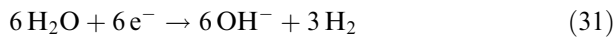

The current efficiency expressions appropriate to this situation can be derived as noted below.

Substitution of Equation 15 into Equation 25 gives

$$J_{\text{NaOH}}^f - J_{\text{NaOH}}^d - J_{\text{HCl}}^f = 2(J_{\text{Cl}_2}^f - J_{\text{Cl}_2}^o) \quad (33)$$

which, in reality, can be simplified to Equation 34 since the role of NaOH feed to the treaters [1] is to raise the pH of the chlorate cell liquor to avoid corrosion problems in the chlorate crystallizer. Thus,  $J_{\text{NaOH}}^f = J_{\text{NaOH}}^d$  and hence:

$$-J_{\text{HCl}}^f = 2(J_{\text{Cl}_2}^f - J_{\text{Cl}_2}^o) \quad (34)$$

It is clear from Equation 34 that if HCl is used to adjust the cell liquor pH, the amount of HCl needed will be given by

$$J_{\text{HCl}}^f = 2J_{\text{Cl}_2}^o \quad (35)$$

On the other hand, if Cl<sub>2</sub> is used to adjust the pH, the chlorine gas feed should be equal to the chlorine gas loss as

$$J_{\text{Cl}_2}^f = J_{\text{Cl}_2}^o \quad (36)$$

Thus, when HCl is used for pH adjustment, the chlorate current efficiency can be shown (from Equations 20 and 35) to be

$$\eta_{\text{ClO}_3} = 1 - \frac{2J_{\text{Cl}_2}^o + 4J_{\text{O}_2}^o}{I/F} \quad (37)$$

With chlorine addition for pH control, the current efficiency is

$$\eta_{\text{ClO}_3} = 1 - \frac{4J_{\text{O}_2}^o}{I/F} \quad (38)$$

The  $I/F$  term in Equations 37 and 38 can be further replaced by  $2J_{\text{H}_2}^o$ , assuming the hydrogen current efficiency to be 100%, that is,

$$\eta_{\text{H}_2} = \frac{J_{\text{H}_2}^o}{I/2F} = 1 \quad (39)$$

Hence, Equations 37 and 38 can be recast as

$$\eta_{\text{ClO}_3} = \frac{J_{\text{H}_2}^o - 2J_{\text{O}_2}^o - J_{\text{Cl}_2}^o}{J_{\text{H}_2}^o} = \frac{100 - 3\% \text{O}_2 - 2\% \text{Cl}_2}{100 - \% \text{O}_2 - \% \text{Cl}_2} \quad (40)$$

if HCl is used to control the pH and

$$\begin{aligned} \eta_{\text{ClO}_3} &= \frac{J_{\text{H}_2}^o - 2J_{\text{O}_2}^o}{J_{\text{H}_2}^o} = \frac{100 - 3\% \text{O}_2 - \% \text{Cl}_2}{100 - \% \text{O}_2 - \% \text{Cl}_2} \\ &= \frac{\% \text{H}_2 - 2\% \text{O}_2}{\% \text{H}_2} \end{aligned} \quad (41)$$

if Cl<sub>2</sub> is used to adjust the pH. The terms %O<sub>2</sub> and %Cl<sub>2</sub> in Equations 42 and 43 refer to the percentages of oxygen and chlorine in the cell gas as

$$\% \text{O}_2 = \frac{100J_{\text{O}_2}^o}{J_{\text{O}_2}^o + J_{\text{Cl}_2}^o + J_{\text{H}_2}^o} \quad (42)$$

$$\% \text{Cl}_2 = \frac{100J_{\text{Cl}_2}^o}{J_{\text{O}_2}^o + J_{\text{Cl}_2}^o + J_{\text{H}_2}^o} \quad (43)$$

If blind current losses [4] are present, the chlorate current efficiency, given by Equations 40 and 41, should be recast as

$$\eta_{\text{ClO}_3} = \left[ \frac{100 - 3\% \text{O}_2 - 2\% \text{Cl}_2}{100 - \% \text{O}_2 - \% \text{Cl}_2} \right] \times \eta_{\text{H}_2} \quad (44)$$

and

$$\eta_{\text{ClO}_3} = \left[ \frac{100 - 3\% \text{O}_2 - \% \text{Cl}_2}{100 - \% \text{O}_2 - \% \text{Cl}_2} \right] \times \eta_{\text{H}_2} \quad (45)$$

However, the blind current losses arising from the electrochemical reaction of  $\text{OCl}^-$  and  $\text{ClO}_3^-$  are completely suppressed by  $\text{Na}_2\text{Cr}_2\text{O}_7$  additions and hence Equations 44 and 45 are not applicable in industrial operations. Note that Equation 40 is in agreement with the expression in [3].

### 3.2. Verification of Equations 40 and 41 for $\eta_{\text{ClO}_3}$

A comparison of  $\eta_{\text{ClO}_3}$  calculated using Equations 40 and 41 is made, using the following data from plant operations at a load of 160 kA obtained with  $\text{Cl}_2$  additions for pH balancing:

$$\% \text{H}_2 = 96.59; \% \text{O}_2 = 2.41 \text{ and } \% \text{Cl}_2 = 1.00$$

Equation 40 yields a  $\eta_{\text{ClO}_3}$  of 93.97% with the above data, whereas, Equation 41 shows  $\eta_{\text{ClO}_3}$  to be 95.00% which is in agreement with the actual production data. It may be pointed out that the precision in measuring  $\% \text{O}_2$  is  $\pm 0.05\%$  and is  $\pm 0.2\%$  for  $\text{Cl}_2$  and hence the error in the  $\eta_{\text{ClO}_3}$  calculations is  $\pm 0.003\%$  for Equation 40 and  $\pm 0.001\%$  for Equation 41.

### 3.3. $\eta_{\text{ClO}_3}$ with oxygen cathodes

One of the interesting concepts examined recently [6] involved the use of  $\text{O}_2$  cathodes instead of  $\text{H}_2$  cathodes to achieve a savings of 1.2 V and possibly eliminate the use of dichromate additions. With oxygen cathodes, the primary cathodic reaction is Equation 46 and not Equation 6:



$\eta_{\text{ClO}_3}$  with oxygen cathodes can be calculated using either Equation 11 or 15 or 25 or 30. However, a simple version is Equation 37 with HCl additions for pH control, and Equation 38 with gaseous chlorine addition for pH adjustment. In either case, it is necessary to know the magnitude of the applied current and the volumetric flow rate of chlorine and oxygen (properly corrected for the unutilized oxygen from the oxygen cathode). These conclusions are in agreement with those in [6].

It is important to mention Vogt's chlorate current efficiency expression [7] involving dimensionless groups which is based on the premise that the chlorate current efficiency is mainly affected by the distribution of two competing reactions: anodic oxidation of  $\text{OCl}^-$  and autooxidation of  $\text{OCl}^-$  and that the electrochemical reactor is either an idealized tubular reactor or a reactor with perfect mixing. These equations are useful for cell design optimization as the efficiency is related to the reactor volume, fluid flow rate, mass-transfer coefficient, the equilibrium constant of Equation 9 and the rate constant of Equation 10 among other parameters, and not for calculating the  $\eta_{\text{ClO}_3}$ .

## 4. Conclusions

Following a rigorous material balance formation for the various species in an electrolytic chlorate cell, expressions for chlorate current efficiency were deduced. A simple version of the current efficiency equation involving only the composition of the gases from the cell is derived when HCl is used for pH adjustment and when gaseous chlorine is employed for pH balancing. It is also shown that these equations can be used when oxygen cathodes are used instead of the conventional hydrogen cathodes.

## Acknowledgements

The authors recognize and are grateful to the late W.W. Ruthel for several excellent discussions on the chlorate efficiency and many other related topics.

## References

1. J.E. Colman and B.V. Tilak, 'Encyclopedia of Chemical Processing and Design', Vol. 51 (Dekker, New York, 1995), p. 126.
2. B. Kaluk, Paper presented at the 14th Annual Chlorine/Chlorate Seminar, ElTech Systems Corporation, 14–16 Sept. (1998).
3. M.M. Jaksic, A.R. Despic, I.M. Csonka and B.Z. Nikolic, *J. Electrochem. Soc.* **116** (1969) 1316.
4. C.-P. Chen, B.V. Tilak and J.W. Quigley, *J. Appl. Electrochem.* **25** (1995) 95.
5. C.-P. Chen and B.V. Tilak, *J. Appl. Electrochem.* **27** (1997) 1300.
6. Y. Baolian and Z. Wenhua, *J. Appl. Electrochem.* **24** (1994) 503.
7. H. Vogt, *J. Appl. Electrochem.* **22** (1992) 1185.